

EFFECT OF BED LENGTH AND VAPOR MALDISTRIBUTION ON STRUCTURED PACKING PERFORMANCE

Tony J. Cai, G. X. Chen, Carl W. Fitz and J. G. Kunesh

Fractionation Research Inc., P.O. Box 2108, Stillwater, OK 74076 USA

ABSTRACT

Recent tests of a 250 m²/m³ structured packing in a 1.22 m diameter column have produced some unanticipated results. Using two quite different systems, mass transfer performance in a relatively short 1.69 m bed was significantly better than previous results in a longer 3.78 m bed. No bed length effect was found on pressure drop. Two different severe vapor maldistributions were studied using a vacuum system with the 1.69 m bed. No significant effect of vapor maldistribution on mass transfer efficiency, capacity and pressure drop was observed. The HETP “hump”, or deterioration of mass transfer performance, previously reported in a 3.78 m bed was again found in the short bed using 11.4 bar butane. However, tests with a 133 m²/m³ packing did not show the hump in a 3.81 m bed. The experimental results are compared to predictions from various literature models.

INTRODUCTION

Fractionation Research, Inc. has been engaged in a comprehensive program of structured packing testing since 1987. The initial series of tests [1] utilized standard test systems at pressures of 0.02 to 27.6 bar and an 18 layer bed which was selected to avoid composition pinches at the ends. The next series of tests utilized controlled maldistribution of the entering liquid to provide guidelines for distributor design and, hopefully, to provide insight into structured packing behavior [2]. The same bed length was used as in the previous studies. The test program reported here was primarily intended to study the effects of vapor maldistribution. For reasons that will be discussed below, a shorter bed than had been used previously was employed. Baseline operations with no maldistribution were run with the short bed for comparison with the older data. In addition, having a short bed installed in the unit, tests were run to further explore the efficiency “hump” phenomenon previously reported with high pressure/high liquid load systems [1]. Zuiderweg [3] had observed that the loss of efficiency causing the “hump” occurred in the lower part of the bed and postulated that the conditions causing it needed about 10 layers of packing to develop. Thus it might be expected that the “hump” would not develop in the short bed.

Vapor Maldistribution Test Design

Packed towers are extensively used for distillation and absorption as they provide good gas-liquid contacting with a low bed pressure drop. Good performance of a packed bed depends critically on vapor and liquid distribution. Controlled liquid maldistribution studies on random packing and structured packing were conducted in commercial scale experiments at F.R.I. [2,4]. Previous vapor maldistribution studies [5,6] have primarily emphasized the hydraulic performance of vapor distributors. However, few studies have been done on their mass transfer performance, particularly in the way of commercial-scale experimental studies. F.R.I. previously conducted controlled vapor maldistribution studies using random packing. It was not surprising that no significant effect of vapor maldistribution had been observed in those tests with random packing because of their significant pressure drops. This was consistent with prior results by Porter et al. [5] who stated that vapor maldistribution only becomes a factor in shallow packed beds where the bed length is less than the column diameter. Structured packing, because of its lower pressure drop, would be expected to be more sensitive than random packing although flow should still even out quite rapidly from the initial point of vapor maldistribution. Consequently, a short bed of structured packing was selected to maximize the chances of observing the effect.

Reports of problems in commercial columns where vapor maldistribution was the suspected cause most often concerned quite large columns. This is consistent with rapid spreading of the vapor. Therefore, because the F.R.I. experimental column is only 1.22 m in diameter, a drastic maldistribution pattern would be needed to see the effect. A secondary consideration was to use patterns compatible with CFD modeling. These considerations led to the selection of a total blockage of a circular region in the center of the bed.

Reported problems in commercial units are most common at vacuum because the pressure drop caused by a good vapor distributor cannot be tolerated. This led to the selection of the xylene system. This is the standard F.R.I. vacuum test system and data taken under good conditions were already available. As discussed below, because a low relative volatility system with few stages was being utilized, total shutdown of vapor flow to part of the bed inlet was selected.

Mass Transfer and Maldistribution

The overall mass transfer at a point, dN , is the product of three independent terms: the overall coefficient, K_{OG} , the interfacial area, a , and the driving force ($Y - Y_i$). Maldistribution of the phases in a packed bed can affect the mass transfer in several different ways. Severe maldistribution of the liquid which results in some of the packing not being wetted obviously reduces the interfacial area, a , as well as causing wide variations in flow rate which affect the mass transfer coefficient. Since vapor penetrates everywhere, vapor maldistribution will affect the mass transfer coefficient but will not influence the interfacial area. Most models for structured packing take HTU_G as being proportional to vapor velocity to the 0.2 to 0.3 power. Thus vapor phase maldistribution needs to be fairly severe for the impact on overall mass transfer to be significant. The impact of maldistribution on driving force is often overlooked but it can be more troublesome. Distortion of the intended phase ratio caused by maldistribution of either phase will result in more or less material being transferred at that point than was planned. This in turn impacts the driving force at

subsequent locations and can lead to a pinch condition. In addition, horizontal concentration gradients, once established, will perpetuate themselves even after radial spreading caused by the packing has eliminated bulk flow variations. Thus the impact of modest amounts of maldistribution becomes more severe as the total amount of material being transferred increases, i.e. at higher values of relative volatility and as more stages are intended to be developed. One of the earliest works to point this out was that by Moore and Rukovena [7] who looked at acceptable distributor quality vs. the number of stages. Billingham and Lockett [8] subsequently used a parallel column model to identify the sensitivity of a separation to small amounts of maldistribution as being a function of both relative volatility and the required number of stages. Consequently, for these tests utilizing few stages and a low relative volatility system, a total blockage of vapor flow to portions of the bed inlet was selected.

Efficiency “Hump”

The mass transfer performance of structured packing for high pressure systems was determined and reported by F.R.I. [1]. A HETP elevated from normal at about 60 to 90% of flood was found and termed an HETP “hump”. Studies on the measured composition profiles along the bed reveal a substantial decrease in the mass transfer efficiency towards the bottom of the bed. Comparisons of measured compositions at different orientations such as west samplers vs. east samplers show obvious flow segregations along the bed. Segregated vapor and liquid flow minimizes the total pressure drop, which happens naturally. It is suggested that the HETP hump is caused by the two phase flow segregation along the bed. Subsequently, a long bed should have a more significant hump than a short bed. Further, the hump may not appear in a short bed if the initial liquid distribution is perfect. This paper reports experimental studies and results obtained with a short bed for the butane system at 11.4 bar.

Past experimental studies conducted by F.R.I. on random packing show no similar hump for high pressure systems [9]. The liquid radial mixing for random packing is much higher than for structured packing. The high degree of radial mixing reduces the magnitude of the two phase flow segregation. This may be one of the reasons why a hump does not occur with random packing. However, it is unknown whether a hump will occur or not for a large structured packing with better radial mixing. To further understand the hump mechanism, additional experimental studies were carried out with a larger structured packing than the one reported previously [1]. Results and discussion are presented in this paper.

EXPERIMENTAL EQUIPMENT

The F.R.I. experimental unit, shown in Figure 1, consists of two commercial scale distillation columns and their support systems. For most operation modes only one column is used. The 1.22 m inside diameter high pressure column is 8.4 m tall from bottom headseam to the top flange and rated for pressures up to 37 bar. The low pressure column is rated from deep vacuum to 11.4 bar and consists of two sections. The lower section is essentially identical to the high pressure column but topped with a 3.66 m tall transition zone. The upper section has a 2.44 m inside diameter and is 6.7 m tall. Each column has a flanged head and clean inner wall design which allows installation of hardware at any location in the column. Sight windows are strategically

located to provide visual observation points inside the column. Couplings are available every 152 mm along the shell which permit temperatures and pressures to be measured and samples to be withdrawn. Samplers are typically installed every 610 mm through the bed with thermocouples in between. Pressure drop is normally measured over the top half, bottom half, and total bed.

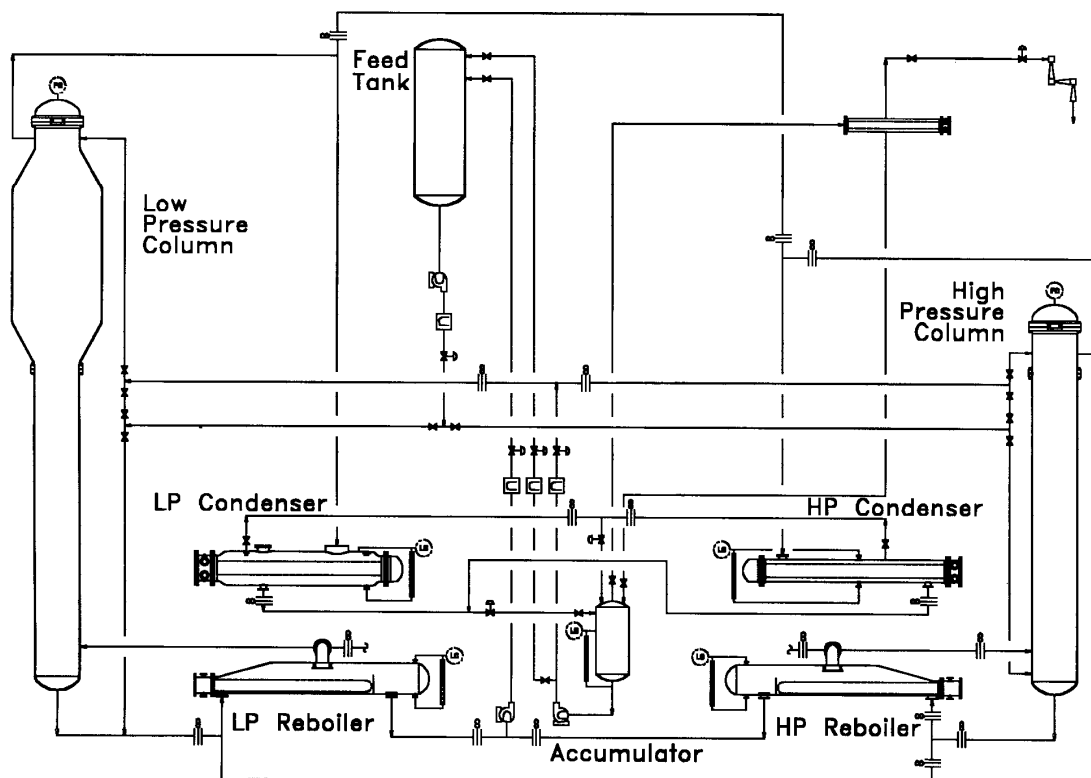

Figure 1. F.R.I. Experimental Unit

Packing

The Mellapak[®] 250.Y used in these tests was a new batch of packing. The packing has a specific area of 250 m²/m³. For the short bed test eight layers of Mellapak was installed for a bed depth of 1.69 m. This packing is essentially the same as that used in earlier tests [1] but is thinner (0.15 mm thick versus 0.2 mm thick) and has a different surface treatment.

Tests were also performed with Intalox[®] structured packing (ISP) size 4T that was supplied by NorPro. It has a surface area of 133 m²/m³ and 14 layers were used for a bed depth of 3.81 m.

Liquid Distributors

Various high quality liquid distributors were used for all the tests. For the short bed structured packing test with the xylene test system the VKG liquid distributor, fabricated by Sulzer Chemtech and shown in Figure 2, was used. This is a trough-orifice type liquid distributor with high open area for vapor flow (45 per cent of

column cross sectional area). It is specifically designed for low pressure high vapor rate systems. It has 128 orifices with a 4.3 mm diameter, which gives a 110/m² pour point density for a 1.22 m diameter column.



Figure 2. VKG Distributor

The F.R.I. tubed drip pan (TDP) distributor was used for the short bed structured packing test with the butane test system. This is a short tube distributor with 121 drip tubes that project below the pan floor to prevent liquid from running along the bottom and above the pan floor to reduce obstruction by dirt and scale. The pan floor is threaded, which allows different sized tubes to be screwed in and out. The inside diameter of the tube for this test was 10 mm. The 3.78 m bed data reported previously made use of 4, 8 and 10 mm tubes. The pour point density was 102/m² and the open area was about 16%. More information about this distributor and the auxiliary devices can be found in the paper published in 1997 [1].

An orifice pan distributor supplied by NorPro was used for the Intalox 4T structured packing tests. This distributor has 121 orifices of 9 mm diameter and 28 rectangular vapor risers. The annular area outside the distributor plus the riser area provided a total open area of about 24%.

Column Configurations and Maldistribution Devices

Figure 3 shows the column configuration for the baseline test of Mellapak 250.Y structured packing, locating packing support grid, samplers, packed bed, thermowells, pressure taps, liquid distributor, and other equipment. This configuration was used for both the xylene and butane operation. The only difference was the liquid distributor. There was no vapor distributor/liquid collector installed below the packed bed. Eight layers of Mellapak 250.Y structured packing were installed to a bed depth of 1.69 m. The VKG liquid distributor was installed 152 mm above the top of the packed bed.

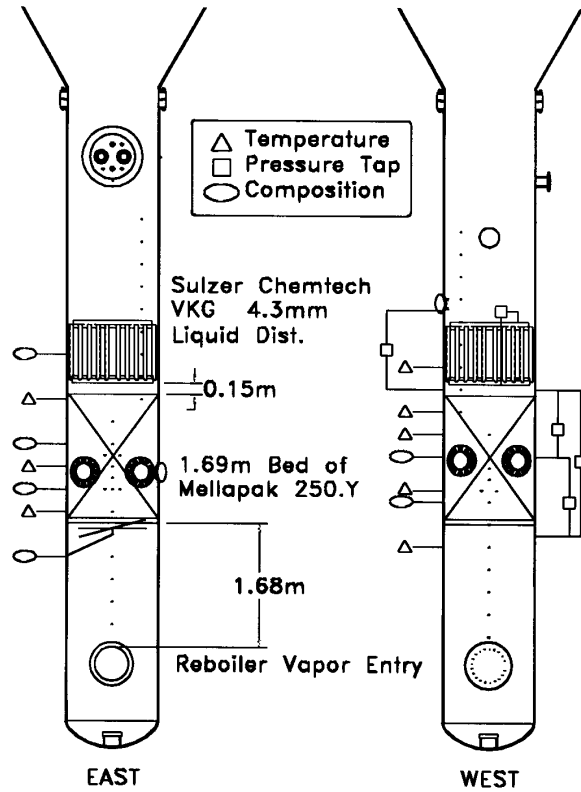

Figure 3. Mellapak 250.Y test 1.69 m bed (baseline)

Figure 4 shows the column configuration for the center block test of Mellapak 250.Y structured packing. After finishing the baseline test, the manway below the packing support grid was opened. Leaving everything unchanged from the baseline test, a circular pan was installed and two additional below bed samplers were added. The circular pan, shown in Figure 5, was centrally placed below the bed against the packing support grid. The pan blocked 50 per cent of the column cross sectional area for vapor flow and collected the liquid descending from the support grid. The collected liquid flowed to the bottom of the column by means of a 102 mm diameter pipe downcomer to a 203 mm diameter 152 mm deep seal pan. The slotted (notched) sleeves were inserted between the bottom of the packing and the circular pan to minimize vapor entering (leaking) into the space above the pan. Since the arms of the cross sampler extended all the way to the column wall, notches were cut in the side walls of the circular pan.

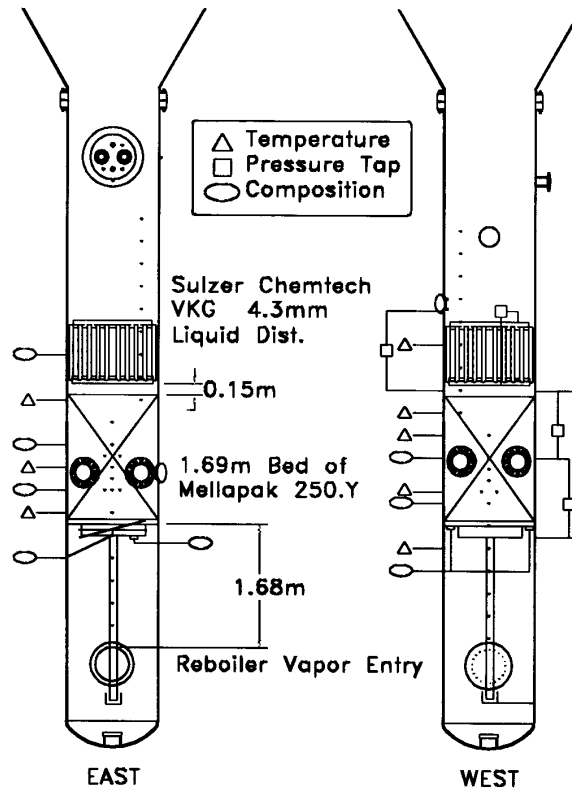

Figure 4. Mellapak 250.Y test 1.69 m bed (center block)

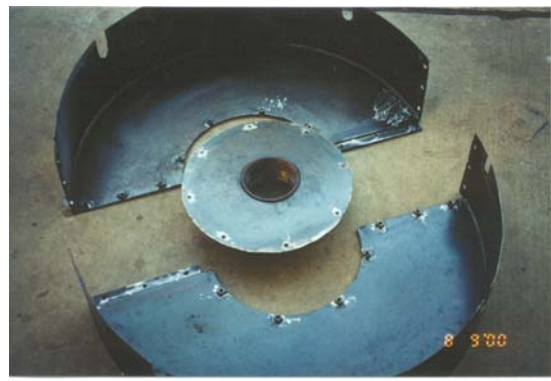

Figure 5. Circular pan for center block test

Figure 6 shows the column configuration for the chordal block test of Mellapak 250.Y structured packing. After finishing the center block test, the manway below the packing support grid was opened. The circular pan was disassembled and taken out through the manway. Leaving everything else unchanged, a segmental pan, shown in Figure 7, was installed. The segmental pan was placed below the bed against the packing support grid on the south side of the column. The pan blocked 30 per cent of the column cross section area for vapor flow and collected the liquid descending from the support grid. The collected liquid flowed to the bottom of the column by means of a 102 mm diameter pipe downcomer to a 203 mm diameter 152 mm deep seal pan. Two sheet metal plates were inserted between the bottom of the

packing and the segmental pan to minimize vapor entering (leaking) into the space above the pan.

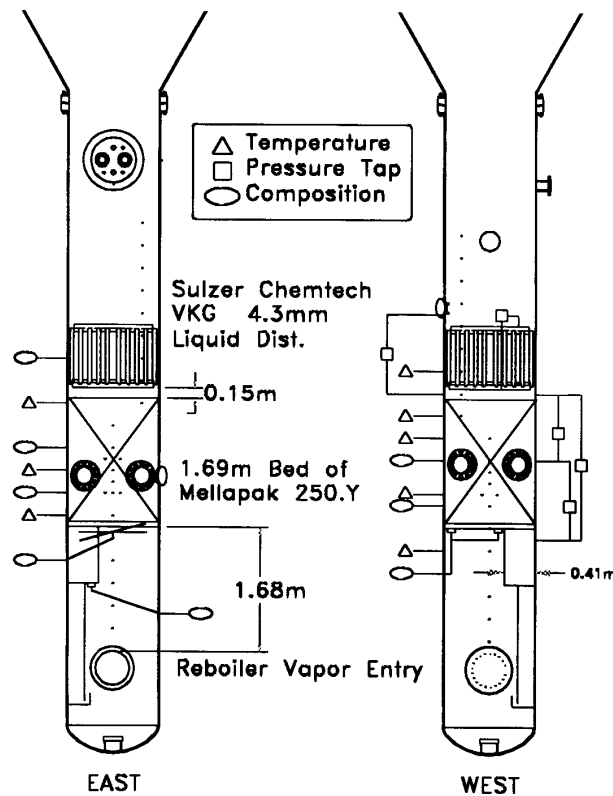

Figure 6. Mellapak 250.Y test 1.69 m bed (chordal block)

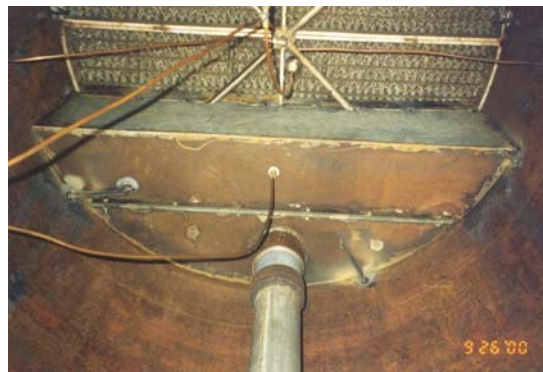

Figure 7. Segmental pan for chordal block test

The column configuration for the Intalox structured packing 4T test is shown in Figure 8, which locates the temperature, composition, and pressure drop measurements. Fourteen layers of Intalox 4T structured packing were installed to a bed depth of 3.81 m. A vapor distributor/liquid collector tray designed and supplied by NorPro was located below the bed and the liquid distributor was positioned 203 mm above the top of the bed.

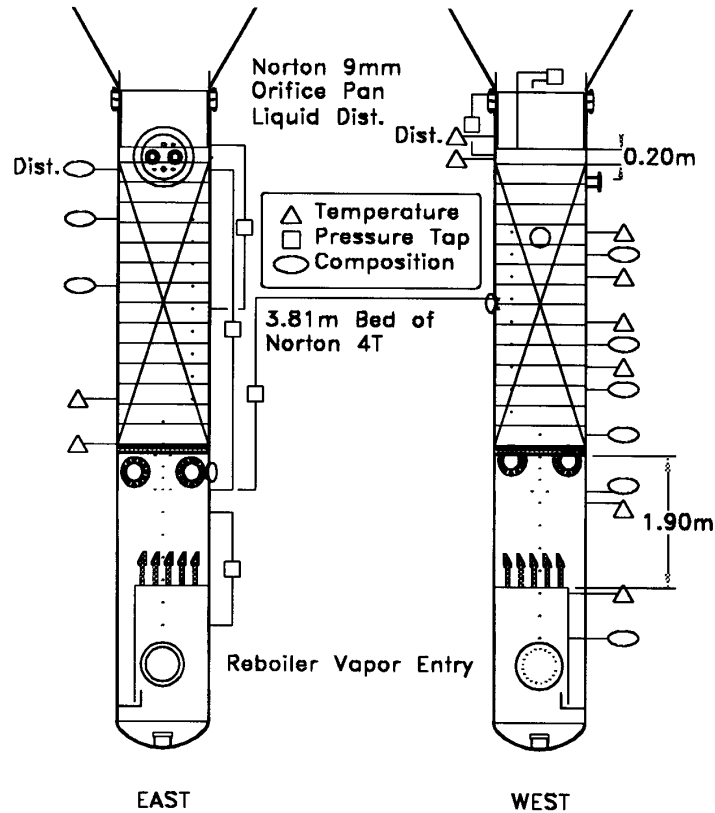

Figure 8. Intalox 4T test 3.81 m bed

RESULTS

Short Bed Baseline Results

efficiency

Figure 9 shows the efficiency measured for the baseline test with the o/p xylene system at 0.13 bar. The HETP was calculated using the liquid compositions from the liquid distributor and below bed cross sampler. Also included in this figure are the F.R.I. previous test results [1] for Mellapak 250.Y structured packing with a 3.78 m bed length. The results are also compared to the predictions computed using the published models of SRP[10], Delft [11], and Billet-Schultes [12]. Compared to the 3.78 m bed length data, the HETP across the middle of the operating range is about 50 mm lower than the previously reported results with a 3.78 m bed. The efficiency models of SRP and Delft tend to over-predict the HETP. The HETP prediction from the Billet-Schultes model agrees well with the data from the 3.78 m bed test. Since the short bed baseline test used a new batch of packing and a different liquid distributor than the previous 3.78 m bed test, check runs were made after the vapor maldistribution tests. The check runs used the same batch of packing and liquid distributor as the baseline test but with a 3.78 m bed length. The HETP of the check runs duplicated the previous results within normal experimental scatter. Therefore, the difference is very likely due to the bed length. This is not predicted by any of the published models.

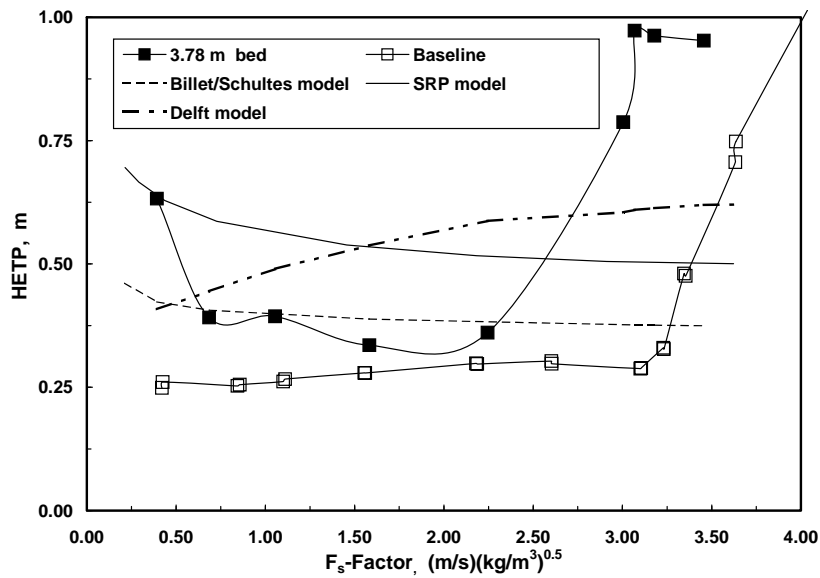

Figure 9. Mellapak 250.Y efficiency, o/p xylene system, 0.13 bar, total reflux

pressure drop

Figure 10 shows the measured packed bed pressure drop results for the baseline test. All results are from total reflux runs. Also included in this figure are the model predictions from Sulzer's PC program Sulpak [13] and the SRP and Delft bed pressure drop models. As shown in this figure, all three models predict bed pressure drop prediction reasonably well. Also included in this figure are the pressure drop results from previous F.R.I. test with a 3.78 m bed length. By comparing the data from the two different bed lengths, it can be seen there is little bed length effect on bed pressure drop.

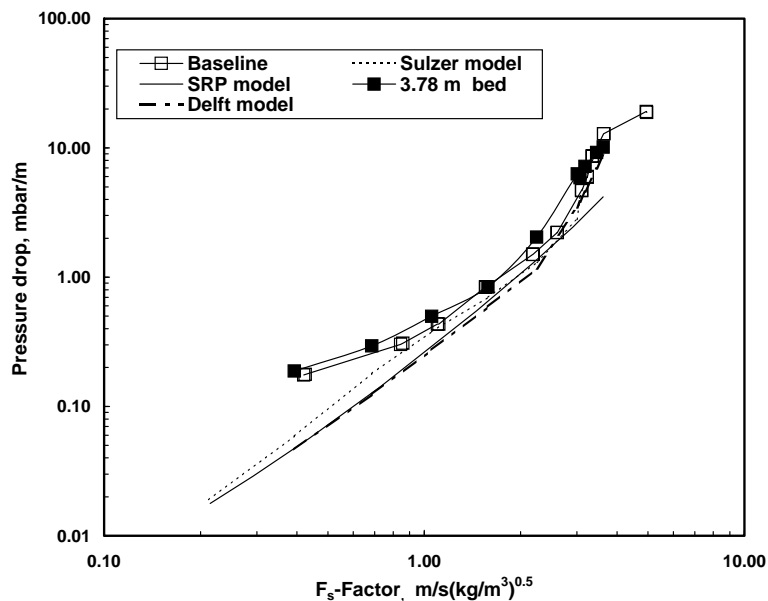

Figure 10. Mellapak 250.Y bed pressure drop, o/p xylene, 0.13 bar, total reflux

Vapor Maldistribution Results

Figure 11 shows the efficiency measured for the vapor maldistribution tests for Mellapak 250.Y structured packing with o/p xylene at 0.13 bar pressure. The HETP for the baseline test is very close to that for both the center block and chordal block tests. The maximum useful capacity of the baseline test is essentially same as that for the center block and chordal block tests. Therefore, for the system tested, vapor maldistributions (both center block and chordal block) do not have any significant effect on packing efficiency and maximum useful capacity.

Figure 12 presents typical composition profiles for the baseline, center block and chordal block tests at different vapor rates. As shown in this figure, the profiles of baseline tests are very similar to those of maldistribution tests, which confirms the efficiency results as shown in the previous figure. For vapor maldistribution tests, two below bed samples were taken in addition to the sample from the center-draw cross sampler. One sample was inside the block area and another outside the block area.

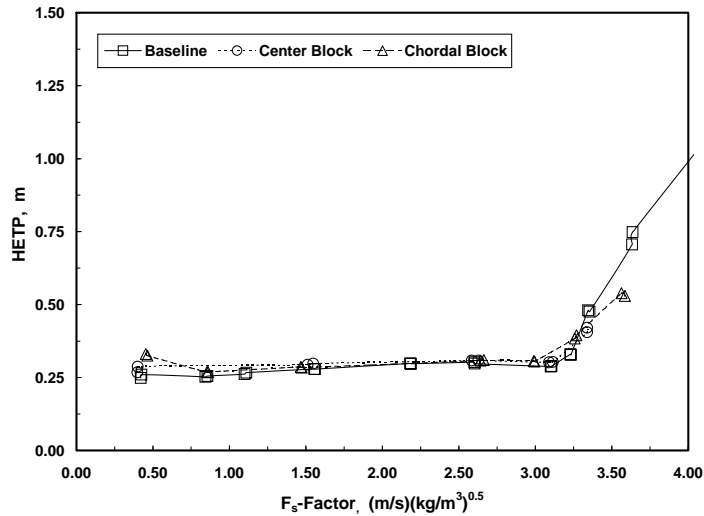

Figure 11. Mellapak 250.Y efficiency, o/p xylene, 0.13 bar, total reflux

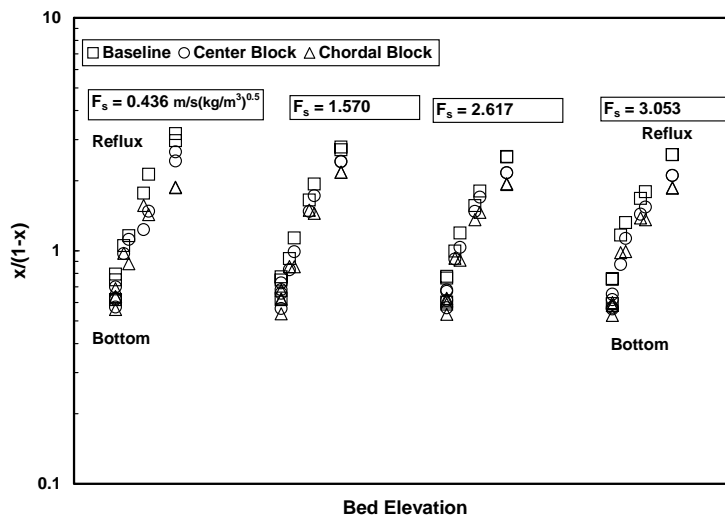

Figure 12 Composition profiles of p-xylene, o/p xylene, 0.13 bar, total reflux

Figure 13 shows the liquid compositions from the three samplers for the center block test. As indicated in this figure, all samplers give similar liquid compositions. The difference in the measured liquid compositions from the three below bed samplers is within experimental accuracy. Similar composition results were obtained for the chordal block test.

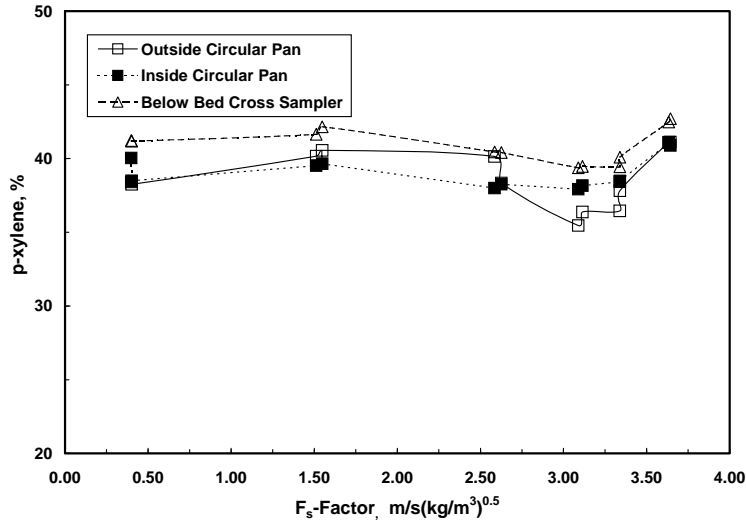

Figure 13 Liquid composition at different locations, o/p xylene, 0.13 bar, total reflux

pressure drop

Figure 14 shows the bed pressure drop at total reflux for the baseline, center and chordal blockage tests. As shown in this figure, the bed pressure drop measurements for all the tests are very close, which indicates that the vapor maldistribution does not affect the bed pressure drop significantly.

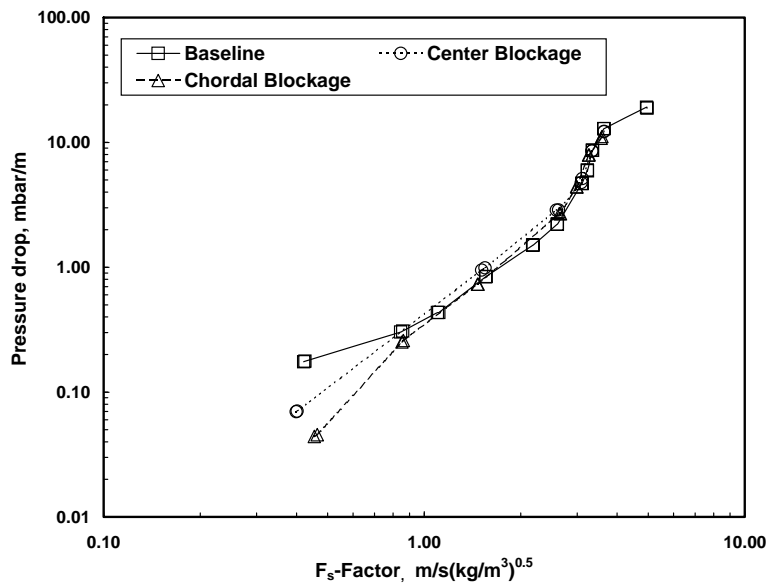

Figure 14 Mellapak 250.Y pressure drop, o/p xylene, 0.13 bar, total reflux

liquid holdup

Gamma ray scanning was used to measure the process density and calculate the liquid holdup. Scanning took place toward the bottom of the bed near the column centerline. Figure 15 compares the holdup versus capacity factor for the baseline test to the center block and chordal block maldistribution tests.

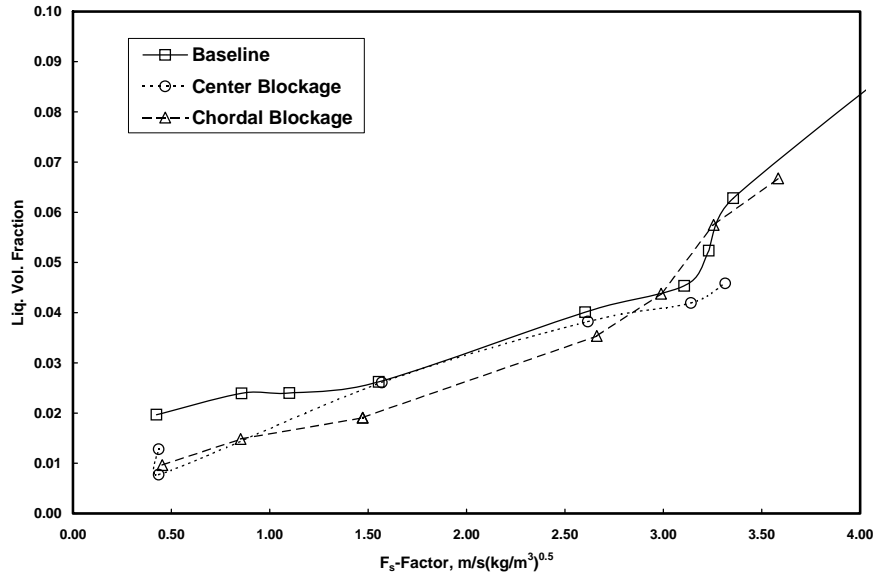

Figure 15. Liquid holdup of Mellapak 250.Y, o/p xylene, 0.13 bar, total reflux

Efficiency “Hump” Results

The mass transfer performance of Mellapak 250.Y was measured under total reflux conditions for the butane system at 11.4 bar pressure. The measured HETP is shown in Figure 16 together with previously measured data for the same packing and same system but a longer 3.78 m bed for comparison. It can be seen that the efficiency “hump” still exists for the 1.69 m bed, which is similar to that found for the 3.78 m bed. However, as shown in Figure 16, the overall HETP for the short bed is lower than that for the 3.78 m bed. This result can be attributed to the bed length effect on HETP as discussed earlier. The predicted results from three different models are also shown in Figure 16 for comparison. All models fail to predict the measured efficiency hump.

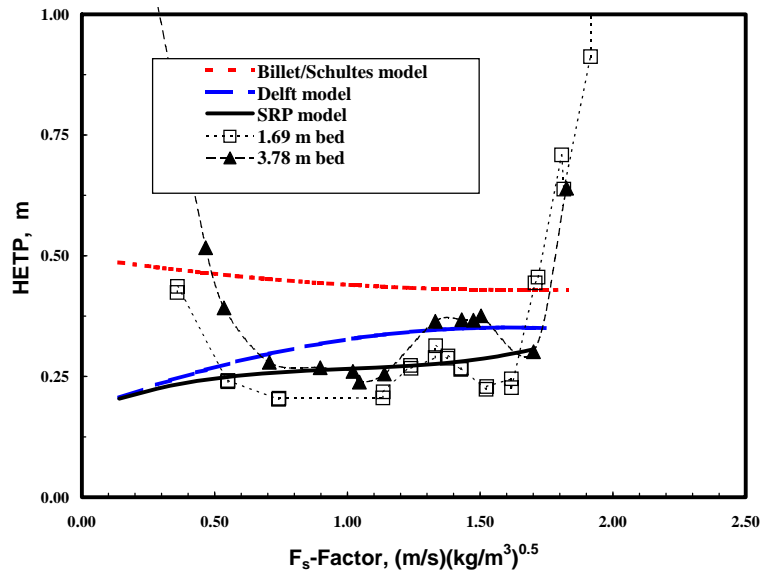

Figure 16. Mellapak 250. Y efficiency, iC_4/nC_4 system, 11.4 bar, total reflux

It has been suggested that the hump may be caused by the decrease in mass transfer efficiency towards the bottom of the bed. Therefore, the HETP for the top and bottom half of the 1.69 m bed was calculated using the measured compositions. These results are compared in Figure 17. It is unexpected to see that the HETP of the bottom half is lower than that of the top half, which is inconsistent with what was found for the 3.78 m bed. Although the reason for the difference is not clear, it can be concluded that the decrease in efficiency towards the bottom half of the bed found for the 3.78 m bed is not the cause of the hump found for the 1.69 m bed. Composition profile plots shown in Figure 18 further substantiate the above argument.

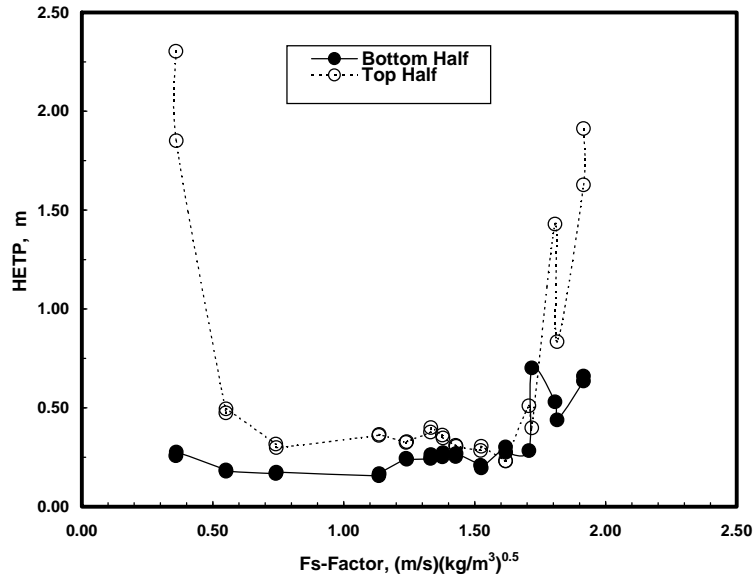

Figure 17 Bed efficiency iC_4/nC_4 system, 11.4 bar, total reflux

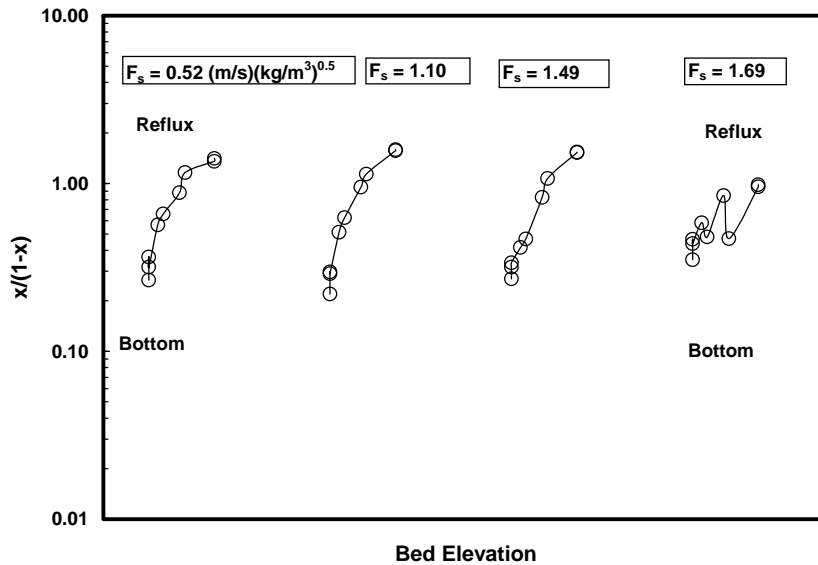

Figure 18 Composition profiles of iC_4 , iC_4/nC_4 system, 11.4 bar, total reflux

Two-phase back mixing may be the cause of the hump in the short bed. It is known that two-phase back mixing can reduce the mass transfer driving force significantly. A maximum mass transfer driving force is obtained when both liquid and vapor phases are in plug flow without any back mixing for systems at low liquid rate and under vacuum conditions. At high liquid loadings for high pressure systems, some of

the crimp channels can be flooded with liquid due to uneven liquid distribution. The liquid flowing down along these flooded channels can entrain vapor and vapor bubbles down with it, resulting in significant vapor back mixing and much reduced mass transfer driving force. Small crimp channels are easier to be flooded than large crimp channels with the same degree of uneven liquid distribution. Consequently, a packing with larger crimp channels than those of Mellapak 250.Y may not have the hump under similar operating conditions. Further experimental measurements were made for Intalox 4T packing with the butane system at 11.4 bar. The specific area of the Intalox 4T structured packing is about half of that of Mellapak 250.Y and has larger crimp channels. The measured HETP for the Intalox 4T packing is shown in Figure 19 and a hump is not found. Figure 20 compares the measured HETP for the two packings. It can be seen that the HETP for the Intalox 4T packing is about twice of that of the base HETP for the Mellapak 250.Y.

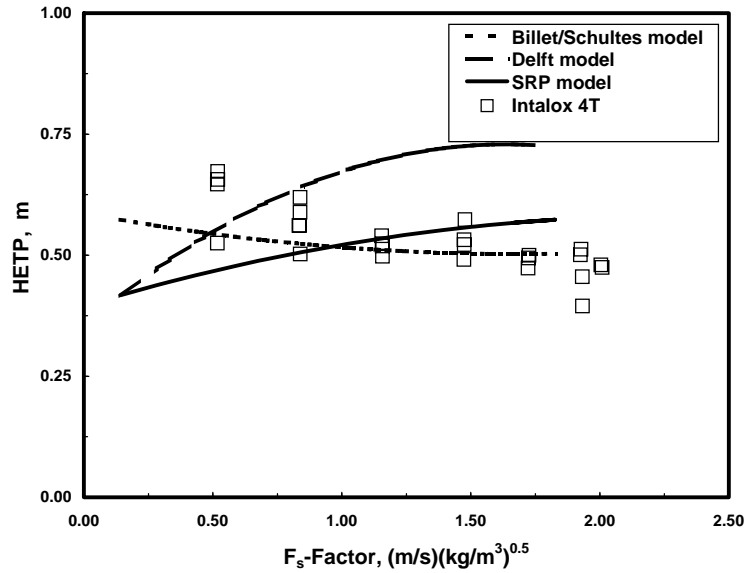

Figure 19. Intalox 4T efficiency, iC_4/nC_4 system, 11.4 bar, total reflux

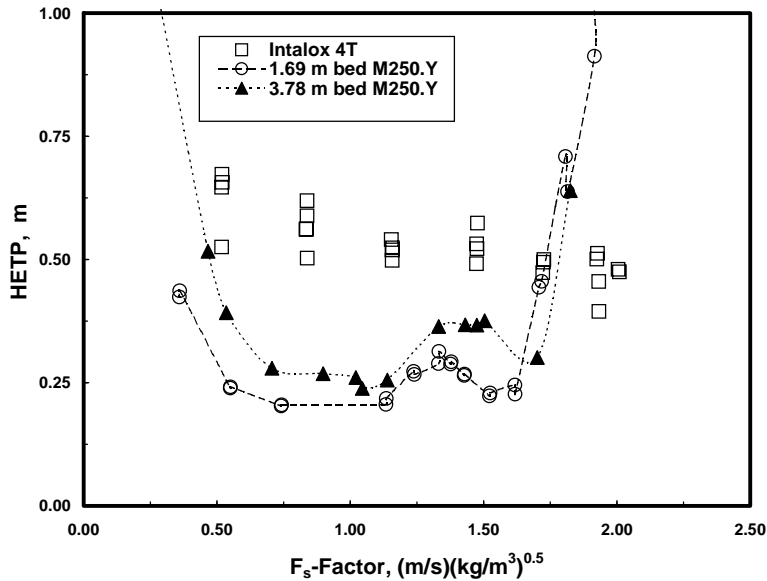

Figure 20. Mellapak 250.Y and Intalox 4T efficiency, iC_4/nC_4 system, 11.4 bar, total reflux

Although a hump is not found for Intalox 4T packing with the butane system at 11.4 bar, it is unknown if there will be a hump or not for systems at higher pressures. Measured experimental data shown above are used to check common literature models. It is found that all literature models fail to predict any efficiency hump. Further modeling research for the structured packing performance based on measured data is underway.

CONCLUSIONS

Mass transfer performance in a relatively short (1.69 m) bed was significantly better than previous results in a longer (3.78 m) bed at total reflux conditions. This was observed for two quite different systems: *o/p* xylene at 0.13 bar and iC_4/nC_4 at 11.4 bar. No bed length effect was found on pressure drop. For the structured packing tested, vapor maldistribution does not have any significant effect on packing efficiency and maximum useful capacity. A very short bed depth is sufficient to suppress initial vapor maldistribution. The HETP hump (deterioration of mass transfer performance in the 70 to 90 per cent of flood region) previously reported with the butane system at pressures in excess of 7 bar was found again with the 250 m²/m³ packing in the short bed. However, tests of another packing with an area of 133 m²/m³ did not show the “hump” at 11.4 bar in a 3.81 m bed. Literature models are unable to predict the HETP hump and the effect of bed length on mass transfer efficiency.

REFERENCES

1. C. W. Fitz, A. Shariat and J. G. Kunesh (1997), IChemE Symp. Series No. 142, pp 829-839.
2. C. W. Fitz, D. W. King and J. G. Kunesh (1999), Trans. IChemE 77, A, 482-486.
3. F. J. Zuiderweg, Z. Olujić and J. G. Kunesh (1997), IChemE Symp. Series No. 142, pp 865-872.
4. J. G. Kunesh, L. L. Lahm, T. Yanagi (1987), Ind. Eng. Chem. Res., 26, 1845-1850.
5. K. E. Porter, Q. H. Ali, A. O. Hassan and A. F. Aryan (1993), Ind. Eng. Chem. Res. 32, 2408-2417.
6. L. A. Muir, C. L. Briens (1986), The Canadian Journal of Chemical Engineering, Vol. 64, 1027-1032.
7. D. Moore and F. Rukovena (1986), 36th Canadian Chemical Engineering Conference, paper 23b.
8. J. F. Billingham and M. J. Lockett (2001), presented at AIChE Annual Meeting, Reno, Nevada, paper 18a.
9. A. Shariat and J. G. Kunesh (1995), Ind. Eng. Chem. Res. 34, 1273-1279.
10. James R. Fair, A. Frank Seibert, M. Behrens, P.P. Saraber and Z. Olujić (2000), Ind. Eng. Chem. Res., 39, 1788-1796.
11. Z. Olujić (2002), presented at AIChE Spring Meeting, New Orleans, Louisiana Topical Conference T1 Session 2 Paper 8.
12. R. Billet and M. Schultes (1999), Trans. IChemE 77, A, 498-504.
13. Sulpak Version 2.1, Sulzer Chemtech Ltd.